



VIVEKANANDHA COLLEGE OF ENGINEERING FOR WOMEN
[AUTONOMOUS INSTITUTION AFFILIATED TO ANNA UNIVERSITY, CHENNAI]
Elayampalayam – 637 205, Tiruchengode, Namakkal Dt., Tamil Nadu.

Question Paper Code: 170001

B.E. / B.Tech. DEGREE END-SEMESTER EXAMINATIONS – NOV. / DEC. 2025

Third Semester

Civil Engineering

U23CE301 – RIGID BODY STATICS AND DYNAMICS

(Regulation 2023)

Time: Three Hours

Maximum: 100 Marks

Answer ALL the questions

Knowledge Levels	K1 – Remembering	K3 – Applying	K5 - Evaluating
(KL)	K2 – Understanding	K4 – Analyzing	K6 - Creating

PART – A

(10 x 2 = 20 Marks)

Q.No.	Questions	Marks	KL	CO
1.	Define Free body diagram with neat sketch.	2	K1	CO1
2.	In a polygon corresponding to a system of forces, if the closing side has a magnitude of zero, what can you say about the system?	2	K2	CO1
3.	State Varignon's theorem.	2	K1	CO2
4.	A single overhanging beam ABC is simply supported at left end A and B, AB being 4m. The overhang BC is 2 m. At the free end C the beam carries a clockwise moment of 20 kN-m. Calculate the support reactions.	2	K2	CO2
5.	Find the moment of inertia of an irregular object about an axis parallel to x-axis with a distance of 25 mm from the x-axis. Area= 1000 mm ² , I _{xx} = 225000 mm ⁴ .	2	K2	CO3
6.	Find the radius of gyration of a circle of 4 cm radius, about x axis passing through the center of the circle.	2	K2	CO3
7.	Define Cone of friction with neat sketch.	2	K1	CO4
8.	A force of 40 N just pulls a body of weight 60 N in horizontal plane, the force being parallel to the plane. Calculate the coefficient of friction.	2	K2	CO4
9.	A train running at 80 kmph is brought to halt after 60 seconds. Find the distance travelled by the train before it come to a halt.	2	K2	CO5
10.	Differentiate direct central impact and oblique central impact with sketch.	2	K2	CO5

PART – B

(5 x 13 = 65 Marks)

- | Q.No. | Questions | Marks | KL | CO |
|--------|---|-------|----|-----|
| 11. a) | Two sphere A and B weighing 100 N and 75 N having the radius of 40 mm and 50 mm respectively are placed inside a container as shown in the fig. Determine the reaction at all contact points. | 13 | K3 | CO1 |

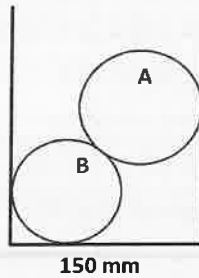

(OR)

- | | | | | |
|--------|---|----|----|-----|
| b) | The lines of action of three forces are concurrent at the origin O. The first force of 10 N is directed from O towards A (3, 0, -3), the second force of 30 N from O towards B (2, -2, 4) and the third force of 40 N from O towards C (-1, 2, 4). Find the resultant and its inclination with X, Y and Z axes. | 13 | K3 | CO1 |
| 12. a) | Find the support reactions of the beam as shown in the figure. | 13 | K4 | CO2 |

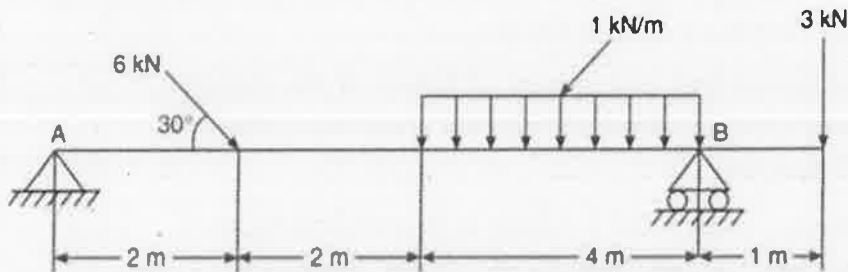

(OR)

- | | | | | |
|----|--|----|----|-----|
| b) | A force system is as shown in Fig. Calculate the resultant in magnitude and direction and its location from point D. | 13 | K4 | CO2 |
|----|--|----|----|-----|

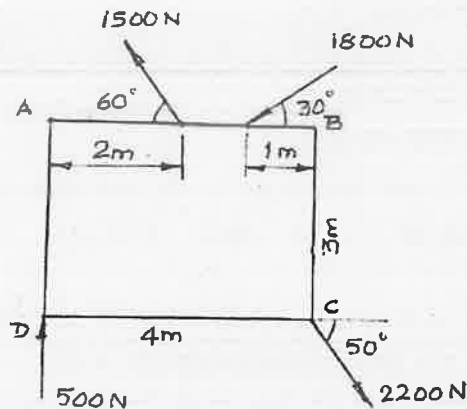

13. a) Find the Moment of Inertia of the area as shown in Fig. about the centroidal axes. 13 K4 CO3

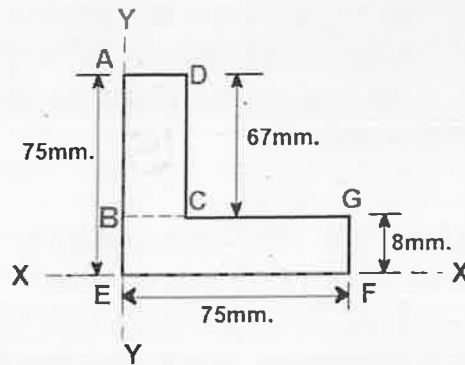

(OR)

- b) Find the Moment of Inertia of the area as shown in Fig. about the centroidal axes. 13 K4 CO3

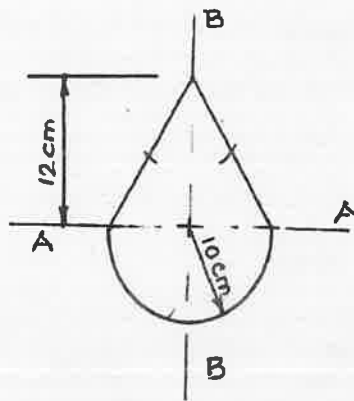

14. a) Determine the least value of the force P to cause motion to impend rightwards. Assume the coefficient of friction under the blocks as 0.2 and the pulley to be smooth. 13 K3 CO4

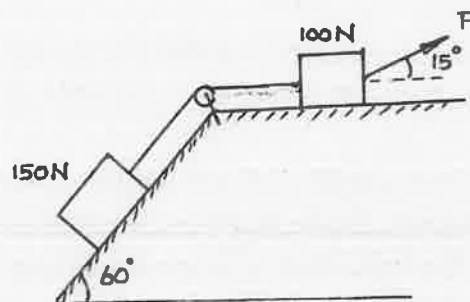

(OR)

- b) A ladder 5 m long and 200 N weight is placed against a vertical wall in a position where its inclination to the vertical is 30°. A man weighing 800 N climbs the ladder. At what position will he induce slipping? The coefficient of friction, μ at all points of contact is 0.2. 13 K3 CO4

15. a) Two trains A and B leave the same station on parallel lines. A starts with a uniform acceleration of 0.15 m/s^2 and attains the speed of 24 kmph, after which, its speed remains constant. B leaves 40 seconds later with uniform acceleration of 0.3 m/s^2 to attain the maximum speed of 48 kmph, after which, its speed remains constant. When will B overtake A? 13 K4 CO5

(OR)

- b) Direct central impact occurs between a 300 N body moving to the right with a velocity of 6 m/sec and a 150 N body moving to the left with a velocity of 10 m/sec. Find the velocity of each body after impact if the coefficient of restitution is 0.8. Also find the loss in kinetic energy. 13 K4 CO5

PART – C

(1 x 15 = 15 Marks)

Q.No.	Questions	Marks	KL	CO
16. a)	Find the forces in all the members of the truss shown in Fig. below.	15	K3	CO1

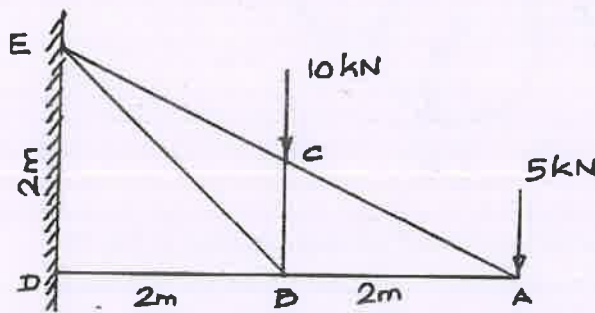

(OR)

- b) A projectile is fired from the top of a mountain peak 150 m high with an initial velocity of 180 m/sec at an angle of elevation of 30° with the horizontal. Neglecting air resistance, find (i) the horizontal distance from the gun to the point where the projectile strikes the ground (ii) the greatest elevation above the ground reached by the projectile. (iii) the total time of flight and (iv) the velocity with which it hits the ground. 15 K4 CO5